

Aluminum Extrusion

EX-83

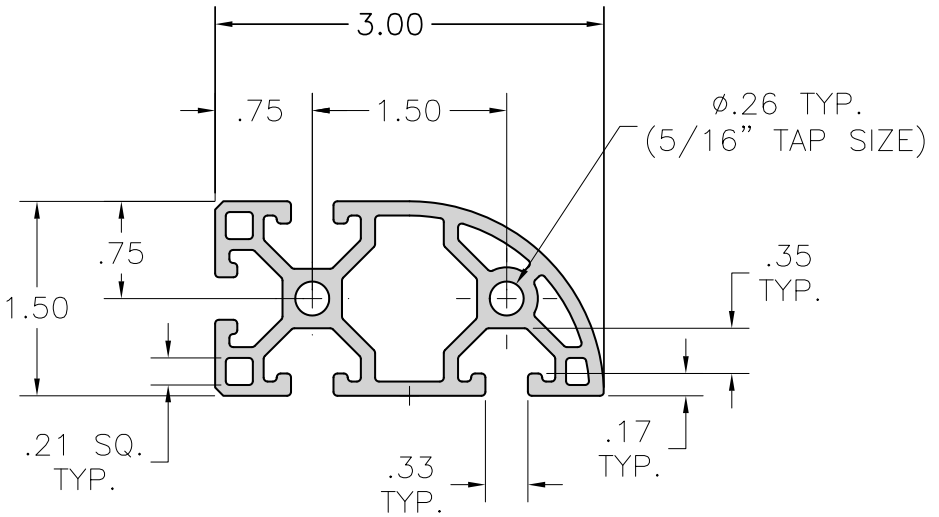

Finish: Clear Anodize
 Material: 6105-T6 Aluminum
 Est. Area: 1.464 Sq In.
 Wt./Ft. 1.722 lbs.
 Std. Length: 96", 192.63"

Section Properties:
 Moment of Inertia in⁴
 Section Modulus in³



1.229
 0.779



0.338
 0.424