

**EX-8**

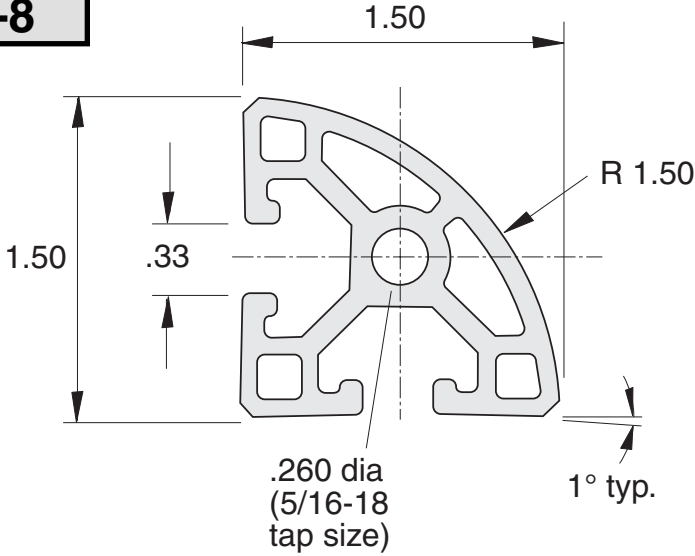

- Finish = Clear anodized
- Material = 6105-T6 Aluminum
- Est. Area = .803 Sq. In.
- Weight/ft = .945 lbs.
- 96", 192.63" Lengths standard.

**Section Properties:**

Moment of Intertia in <sup>4</sup>	.156
Section modulus in <sup>3</sup>	.188

Load condition:  
Fixed at both ends, load at center  
Deflection = y (inches)

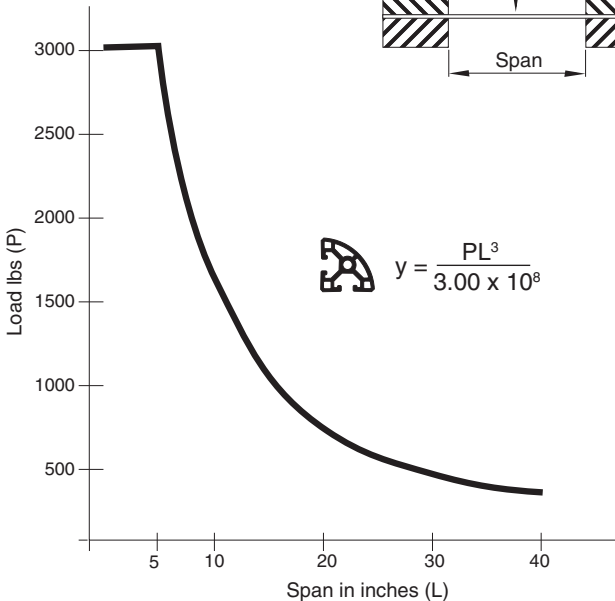
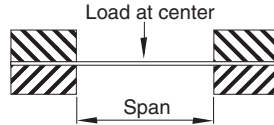

**EX-8**

Load condition:  
Fixed at one end, sliding at one end,  
load at center  
Deflection = Y (inches)

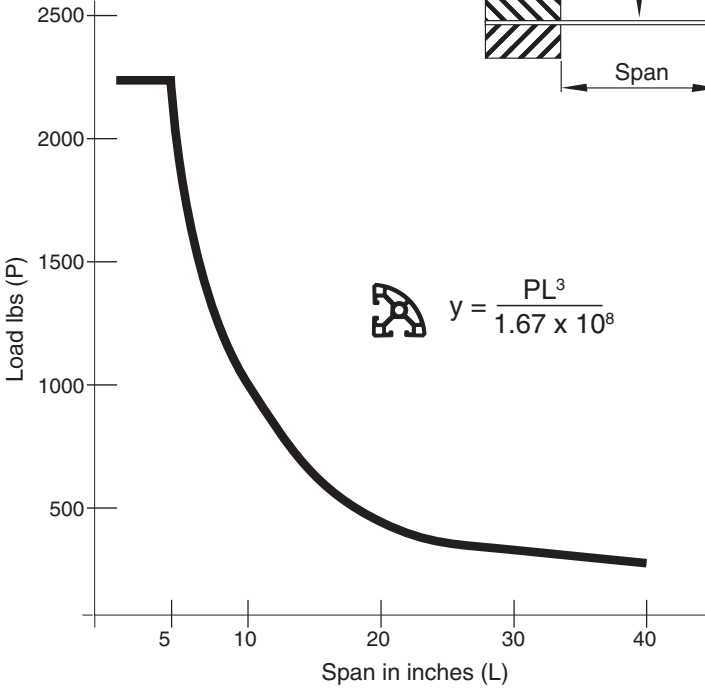
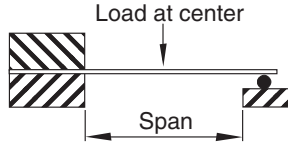

Load condition:  
Fixed at one end,  
load at unsupported end  
Deflection = Y (inches)

