

EX-3
BLX-3

Clear Anodized

Black Anodized

- Material = 6105-T5 Aluminum
- Est. Area = 3.188 Sq. In.
- Weight/ft = 4.037 lbs.
- 96", 144.25" (clear), 192.63" Lengths standard.

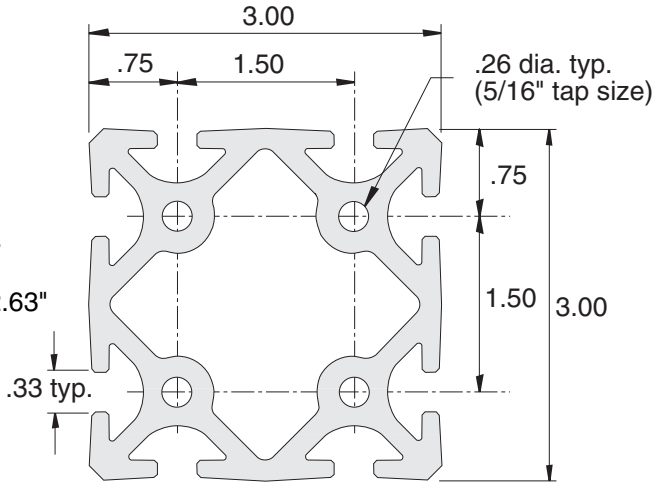

Section Properties:

Moment of Inertia in ⁴	3.26
Section modulus in ³	2.173



Load condition:
Fixed at both ends, load at center
Deflection = y (inches)

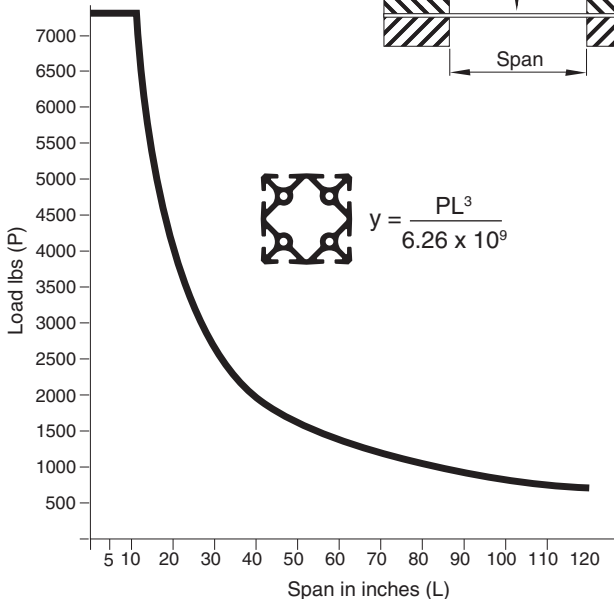
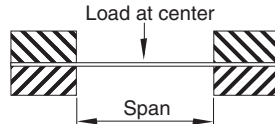

Clear Anodized

EX-3

Black Anodized

BLX-3

Load condition:
Fixed at one end, sliding at one end,
load at center
Deflection = Y (inches)

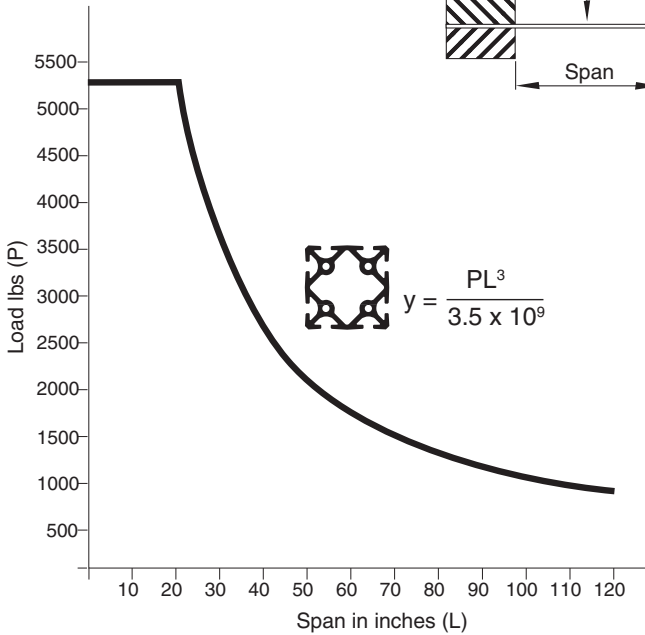

Load condition:
Fixed at one end,
load at unsupported end
Deflection = Y (inches)

