

EX-2
BLX-2

Clear Anodized

Black Anodized

- Material = 6105-T5 Aluminum
- Est. Area = 2.051 Sq. In.
- Weight/ft = 2.471 lbs.
- 96", 144.25" (clear), 192.63" Lengths standard.

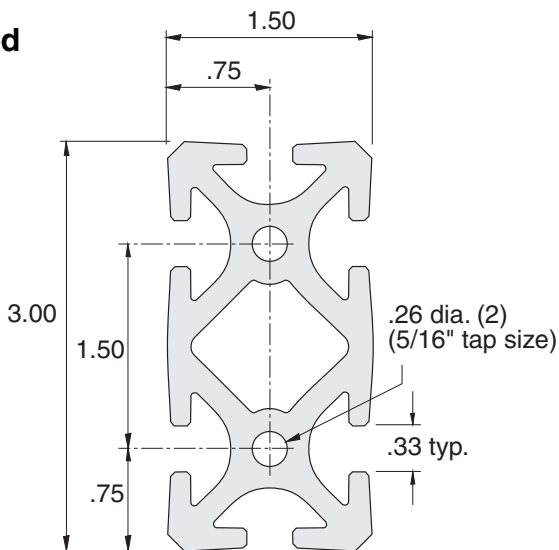

Section Properties:

Moment of Intertia in⁴

Section modulus in³



1.76

1.173



.481

.641

Load condition:
Fixed at both ends, load at center
Deflection = y (inches)

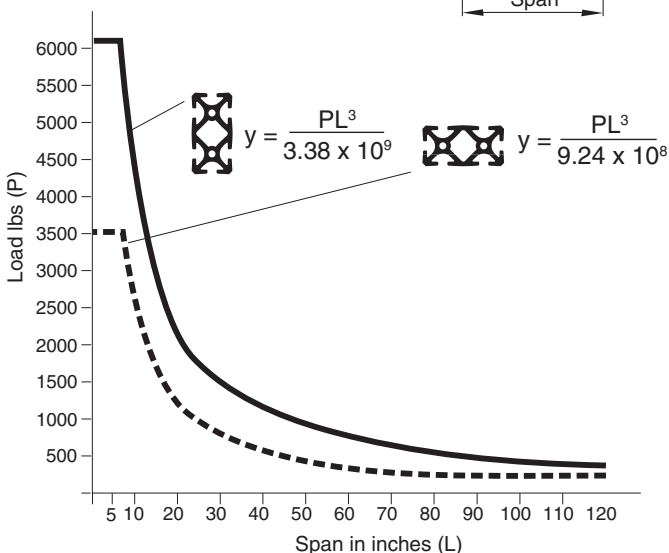
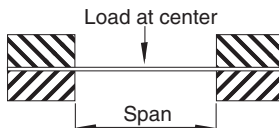

Clear Anodized

EX-2

Black Anodized

BLX-2

Load condition:
Fixed at one end, sliding at one end,
load at center
Deflection = Y (inches)

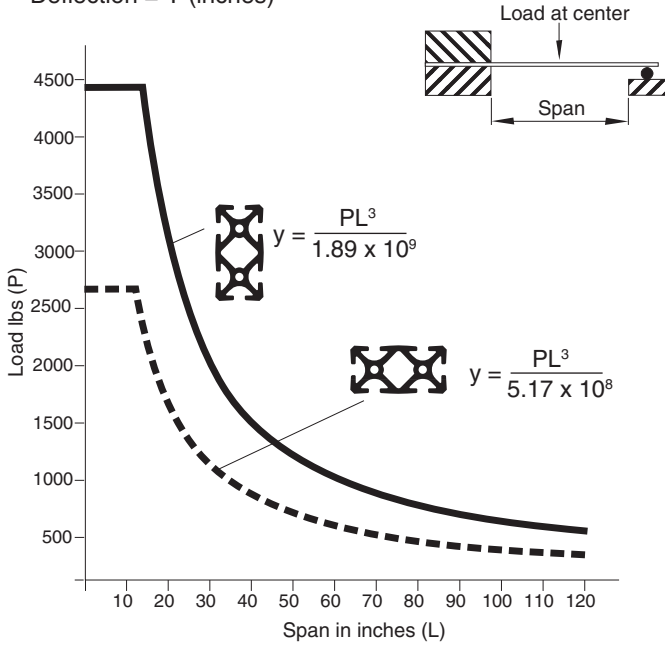

Load condition:
Fixed at one end,
load at unsupported end
Deflection = Y (inches)

