

EX-1
BLX-1

Clear Anodized

Black Anodized

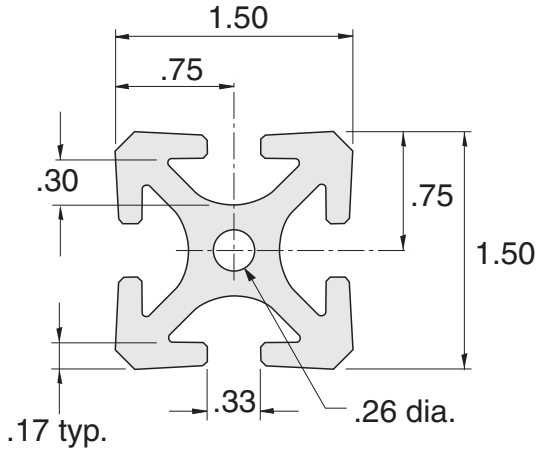

- Material = 6105-T5 Aluminum
- Est. Area = 1.164 Sq. In.
- Weight/ft = 1.4522 lbs.
- 96", 144.25" (clear), 192.63" Lengths standard.

Section Properties:

Moment of Intertia in⁴ .242
 Section modulus in³ .323

Load condition:
 Fixed at both ends, load at center
 Deflection = y (inches)

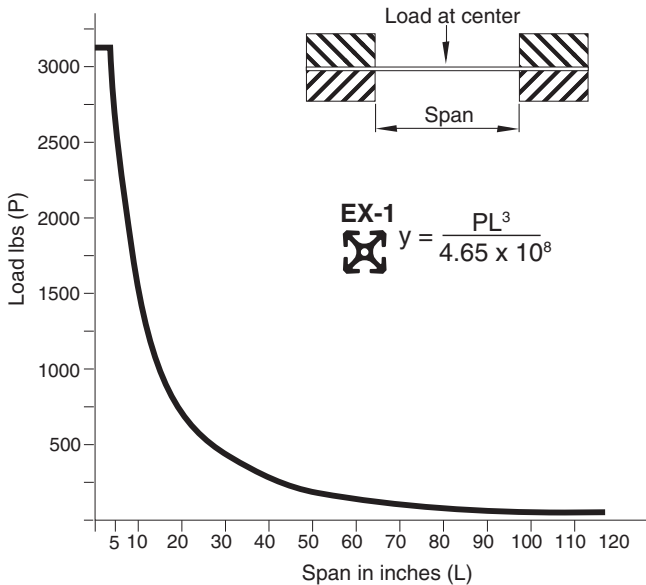

Clear Anodized

EX-1

Black Anodized

BLX-1

Load condition:
Fixed at one end, sliding at one end,
load at center
Deflection = Y (inches)

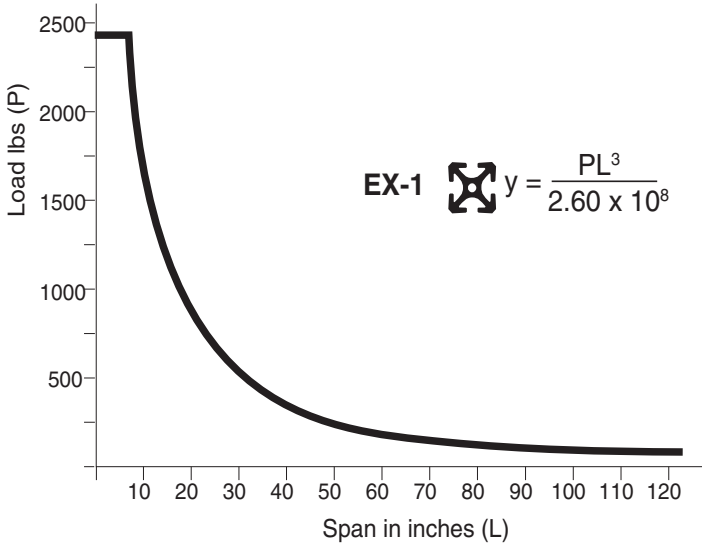
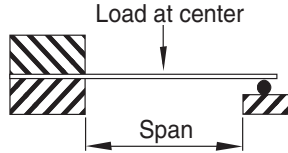

Load condition:
Fixed at one end,
load at unsupported end
Deflection = Y (inches)

