

EF-36

5/16" SLOTS

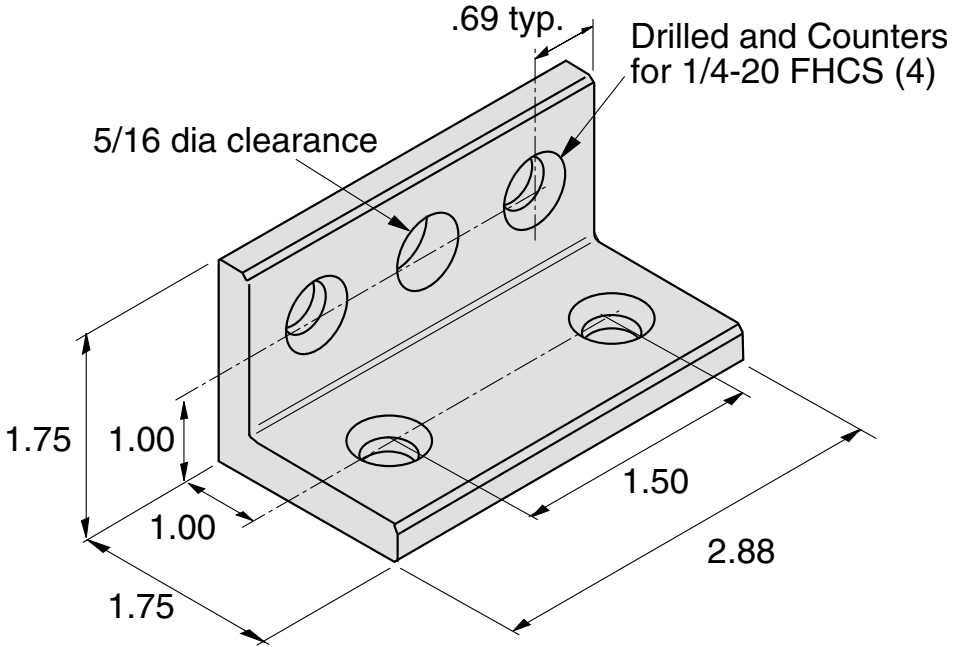

Note: See part no EB-38 for example

Recommended
Hardware
(4) EF-157-.63
(2) EF-2A T-nut

Material - Aluminum
Finish - Clear Anodize